



IMPORTANT FOR FUTURE REFERENCE	
Please complete this information and retain this manual for the life of the equipment:	
Model #:	_____
Serial #:	_____
Date Purchased:	_____

Installation & Operation Manual

Direct Steam Power Tilting or Stationary Kettles

DMT-30S, DMT-40S, DMT-60S, DMS-30S, DMS-40S & DMS-60S



Model DMT-S

WARNING

Improper installation, adjustment, alteration, service or maintenance can cause property damage, injury or death. Read the installation, operating and maintenance instructions thoroughly before installing or servicing this equipment.

SOUTHBEND STEAM

 **MIDDLEBY** A Middleby Company

1100 Old Honeycutt Road Fuquay-Varina, North Carolina 27526 USA

www.southbendnc.com

SAFETY PRECAUTIONS

Before installing and operating this equipment, be sure everyone involved in its operation is fully trained and aware of precautions. Accidents and problems can be caused by failure to follow fundamental rules and precautions.

The following symbols, found throughout this manual, alert you to potentially dangerous conditions to the operator, service personnel, or to the equipment.



This symbol warns of immediate hazards that will result in severe injury or death.



This symbol refers to a potential hazard or unsafe practice that could result in injury or death.



This symbol refers to a potential hazard or unsafe practice that could result in injury, product damage, or property damage.



This symbol refers to information that needs special attention or must be fully understood, even though not dangerous.

IMPORTANT NOTES FOR INSTALLATION AND OPERATION

WARNING

This is the safety alert symbol. It is used to alert you to potential personal injury hazards. Obey all safety messages that follow this symbol to avoid possible injury or death.

WARNING

FOR YOUR SAFETY:

Do not store or use gasoline or other flammable vapors or liquids in the vicinity of this or any other appliance.

WARNING

Improper installation, operation, adjustment, alteration, service or maintenance can cause property damage, injury or death. Read the installation, operating and maintenance instructions thoroughly before installing, operating or servicing this equipment.

WARNING

Disconnect the power supply to the appliance before cleaning or servicing.

CAUTION

Operating, testing, and servicing should only be performed by qualified personnel.

NOTICE

This product is intended for commercial use only. NOT FOR HOUSEHOLD USE.

NOTICE

This manual should be retained for future reference.

RETAIN THIS MANUAL FOR FUTURE REFERENCE.

Table of Contents

Important Notes For Installation and Operation	2
Service Connections	4
Installation	5
Introduction	6
Basic Functions.....	6
Operation	7
Maintenance	8
Hydraulic System Adjustments (DMT-S Only)	9
Cleaning.....	10
Troubleshooting	11
Appendix A – Material Safety Data Sheets	12

SERVICE CONNECTIONS

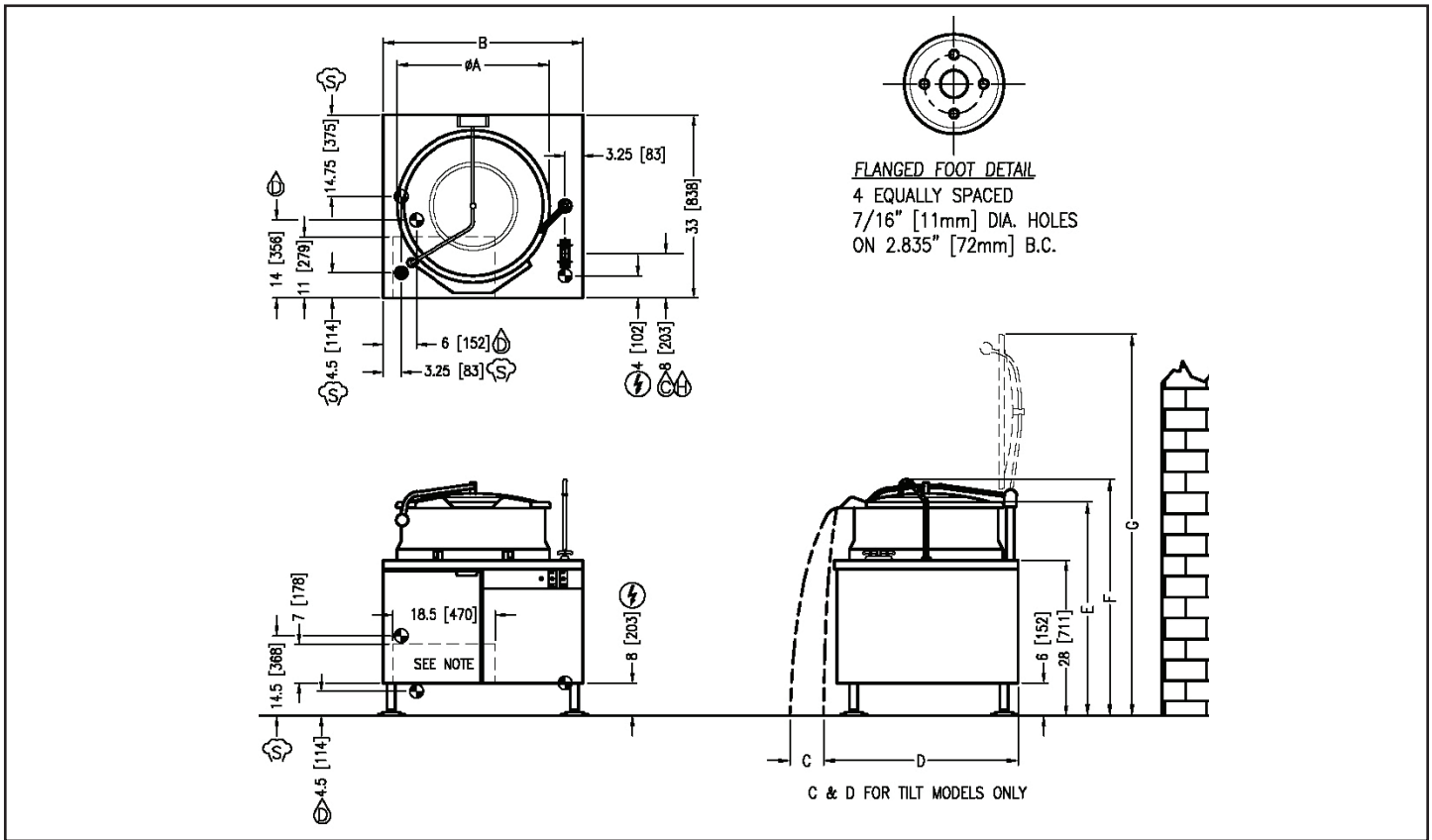

SERVICE CONNECTIONS

- COLD WATER: 3/8" O.D. tubing to faucet.
- HOT WATER: 3/8" O.D. tubing to faucet.
- DRAIN: 1-5/8" (41.275 mm) O.D. tubing piped to open floor drain. No solid connection.
- ELECTRICAL CONNECTION: (DMT-S models only) 1/2" conduit connection to controls. Unless otherwise specified, field wire electrical connection to be 115V, 60 Hz, single Phase, 10 Amps with grounding wire.
- STEAM SUPPLY: 3/4" (19 mm) IPS for incoming steam. MIN 5PSI (34kPa), MAX 30 PSI (207 kPa). Important: Pressure reducing valve required if incoming steam pressure exceeds the kettle rating.

DIMENSIONS

MODEL	CAPACITY	A	B	C	D	E	F	G
DMT-30S	30 Gallons (114 liters)	24" (610)	36" (914)	16" (406)	39" (991)	37.25" (946)	41.5" (1054)	65.25" (1657)
DMS-30S								
DMT-40S	40 Gallons (151 liters)	26" (660)	36" (914)	15" (381)	40" (1016)	38.38" (975)	42.5" (1080)	68.25" (1733)
DMS-40S								
DMT-60S	60 Gallons (227 liters)	29.5" (749)	42" (1067)	16" (406)	43" (1092)	41.12" (1045)	47.62" (1210)	74.25" (1886)
DMS-60S								

SPECIFICATIONS

MODEL	SHIPPING WEIGHT	MINIMUM CLEARANCE		MODEL	SHIPPING WEIGHT	MINIMUM CLEARANCE		MODEL	SHIPPING WEIGHT	MINIMUM CLEARANCE	
DMT-30S	475 lbs. [215 kg]	SIDES	0	DMT-40S	525 lbs. [238 kg]	SIDES	0	DMT-60S	600 lbs. [272 kg]	SIDES	0
DMS-30S	375 lbs. [170 kg]	BACK	0	DMS-40S	400 lbs. [181 kg]	BACK	0	DMS-60S	500 lbs. [227 kg]	BACK	0

As continued product improvement is a policy of Southbend Steam, specifications are subject to change without notice.

INSTALLATION INSTRUCTIONS

UNPACKING

IMMEDIATELY INSPECT FOR SHIPPING DAMAGE

Immediately after unpacking, check for possible shipping damage. If the appliance is found to be damaged, save the packaging material and contact the carrier within 15 days of delivery.

We cannot assume responsibility for damage or loss incurred in transit.

INSTALLATION

WARNING

Electrical and grounding connections must comply with applicable portions of the National Electrical Codes.

WARNING

Plumbing connections must comply with applicable health, safety and plumbing codes.

1. Select a location to provide drainage directly below the draw-off valve. Allow sufficient rear clearance from the wall for the kettle cover to lift upright freely without obstructions. Allow for clearance to side service panels.
2. Level the unit. Then mark anchoring hole locations through flanged adjustable feet.
3. With hole locations marked, drill holes and insert expansion plugs to accommodate 5/16" size lag bolts.
4. Reposition the kettle. Check the level again.
5. Bolt the kettle down and seal with a high grade sealing compound. Sealant must be applied not only to bolt heads but around the flanges and must be making contact with floor surface to meet N.S.F. requirements. Wipe off excess sealant immediately.
6. Connect the steam line to the kettle (3/4" i.p.s., 5 psi minimum to 30 psi maximum, or 45 psi with optional high pressure operation).
7. If the incoming steam pressure is greater than the kettle maximum operating pressure, then a pressure reducing valve (supplied by others) must be installed in the line.
8. Connect hot and cold water supply to the faucet.
9. Connect the kettle condensate return line to a 2" open air gap drain or to a boiler return line. Each kettle return line must have a suitable steam trap (supplied by others). Boiler return lines must have a check valve (supplied by others).
10. A control box with a power supply equivalent to electrical rating of the unit should be located nearby. A waterproof electrical connection for the power supply to the unit must be provided (for Power tilting models only).
11. The relief valve on the kettle must not be adjusted or closed off as it is set to relieve excess pressure in the kettle.
12. If large amounts of water accumulate in the steam line, it will be necessary to install one or more ball float traps (supplied by others) in the line to eliminate the water.
13. A steam line pressure gauge (supplied by others) is also recommended to determine the actual amount of steam coming to the kettle.
14. Turn unit on when electrically connected, then check for proper operation.

INTRODUCTION

Description

The Southbend Steam DMS-S and DMT-S kettles are direct steam models mounted in a modular cabinet base. The DMS-S is a modular stationary model supplied with a tangent draw-off valve for food product removal.

The DMT-S is a direct steam modular tilting model. It has a hydraulic pump and cylinder to tilt the kettle to any angle between zero and ninety degrees for complete emptying of food products. Tilting models include a pan carrier that holds a 12" x 20" pan. (Pan not supplied.)

Both of these units employ kettles which are direct steam operated pressure vessels with a double wall stainless steel construction forming a steam chamber (jacket) around the lower two thirds of the kettle. These kettles are furnished with a steam control valve and a hot and cold water fill faucet mounted on the stainless steel counter top. Every kettle has a pressure relief valve. Access to the inner cabinet area for installation or service is through the removable side panels or the doors on the front of the unit.

The kettle bowl is the container for the food product which ideally should be a liquid or semi-liquid for complete contact with the bowl surface to fully absorb the heat transmitted through the surface from the steam in the kettle jacket.

These kettles are intended to be permanently floor mounted with adjustable flanged feet.

BASIC FUNCTIONS

CAPACITIES

All models end with 20, 30, 40 and 60 to indicate the capacity of that kettle in gallons. For example, model DMT-40S indicates a tilting two thirds jacketed steam kettle mounted in a cabinet base, with a capacity of 40 gallons. A DMS-40S is stationary.

CONTROLS

The electric controls are in the upper right area of the kettle front. One control is an ON-OFF switch for the tilting mechanism. The second control, in the up position tilts the kettle forward to full tilt. In the down position the kettle is lowered to full down. Stopping the up or down control will hold the kettle at any position the kettle is stopped.

PAN CARRIER (DMT-S MODEL ONLY)

The DMT-S (tilting) model is equipped with a pan carrier. The pan support is made of stainless steel and is removable, without tools, for cleaning. It holds one 12" x 20" pan and will locate the pan in a horizontal position not more than 2" from the kettle lip throughout the tilting operation.

SWING DRAIN

Each kettle has a swing drain to use with the draw-off valve. It is removable, without tools, and has a removable strainer.

HYDRAULIC SYSTEM (DMT-S MODEL ONLY)

The hydraulic system in every DMT-S kettle has been adjusted and tested at the factory and no further adjustment should be needed. If the unit fails to operate properly, all service work must be performed by a qualified service agent.

OPERATION

 **WARNING**

Do not tilt kettle with lid down.

 **WARNING**

The kettle is hot. Use care when operating and servicing the kettle.

OPERATING INSTRUCTIONS

1. With tilting units, turn the power switch on only during tilt cycles. Running the hydraulic power unit continuously may overheat or damage the system.
2. Push the toggle switch to the up position. Check that the kettle begins to rise. Allow the kettle to travel to its full up position then push the toggle switch to the down position and the kettle will return to the original position. The kettle will stop and hold its position at any point along the travel path if the toggle switch is released.
3. Check that the draw-off valve is closed.
4. Fill the kettle with product to the desired level.

NOTICE

Food products with milk or egg base should be placed into a cold kettle before the cooking operation begins. Avoid sudden contact of these food products in a hot kettle, the food will stick to the surface.

5. Slowly turn the steam control valve to the full open position (counterclockwise). The kettle will begin to heat. It is important that the condensate return valve located on the bottom of the kettle be opened daily before starting the unit up to allow any accumulation of water to be emptied. Otherwise the efficiency of the kettle is reduced.
6. Slowly open the relief valve to allow all air to escape. Stay clear of the valve outlet during this operation to avoid very hot steam.
7. Regulate the steam control valve depending on the type of food being prepared.
8. When the food is cooked, turn off the steam, remove the food through the draw-off valve or by tilting. Clean the kettle immediately to prevent residue from drying on the kettle bowl.

MAINTENANCE

KETTLE

SAFETY VALVE MAINTENANCE AND TESTING

CAUTION

Under normal operating conditions a “try lever test” should be performed every two months. Under severe service conditions, or if corrosion and/or deposits are noticed within the valve body, testing must be performed more often. A “try lever test” should also be performed at the end of any non-service period.

CAUTION

Hot, high pressure fluid may be discharged from body drain and vent during “try lever” test. Care must be taken to avoid any bodily contact.

CAUTION

High sound levels may be experienced during “try lever” test. Wear proper safety equipment and exercise extreme care! Test at, or near, half of the operating pressure by holding the test lever fully open for at least two seconds to flush the valve seat free of sediment and debris. Then release lever and permit the valve to snap shut.

If lift lever does not activate, or there is no evidence of discharge, turn off equipment immediately and contact a licensed contractor or qualified service personnel.

HYDRAULIC SYSTEM (DMT-S ONLY)

SERVICE

Set up regular schedule for checking the oil temperature, hydraulic hoses and keeping the equipment clean. A thick layer of dirt acts as an insulation and prevents the hydraulic system from getting rid of heat.

The hydraulic system has been adjusted and tested at the factory and no further adjustment should be needed. If the unit fails to operate properly, all service work must be performed by a qualified service agent.

1. Hot oil in the Hydraulic System is one of the primary causes of poor operation. When the tilt system is not in use turn MOTOR switch off.
2. Inspect hydraulic hoses for wear and aging.
3. Check that fluid levels are kept full.
4. To replace oil, fill through filler breather.
5. Use proper oil as specified by factory or equivalent.
6. Check the cleanliness of the oil strainer inside the reservoir once per year. This item can be washed in clean Varsol.
7. Change the breather filter once per year.
8. Change the oil once every two years.

HYDRAULIC SYSTEM ADJUSTMENTS (DMT-S ONLY)

There are three controls available on this power unit. The first is an adjustable relief valve mounted into the custom aluminum manifold block. The other two control the linear speed of the actuator.

RELIEF VALVE

The relief valve is located underneath an aluminum hexagon cover on the side of the custom manifold block. This relief valve is factory set to 825 P.S.I. and locked and should not be adjusted.

If adjustments are necessary, remove the hexagon cover which will give access to the relief valve screw. With the pump running, and with a suitable flat blade style screwdriver, rotate the screw clockwise to increase pressure, and anti clockwise to decrease pressure. While this operation is being carried out some oil will leak down the threads of the adjusting screw.

To obtain the pressure required, a pressure gauge will have to be located in the circuit. The best location is on the cylinder hose. To set the pressure, energize the solenoid to extend the cylinder fully and thus "deadhead" the system. The pressure can be set as indicated above. When adjustment is complete, replace the hexagon cover. This will seal the relief valve area. The actual factory set pressure is noted on the label and should not be exceeded as this affects the HP draw on the electric motor.

FLOW CONTROL

There are two flow control valves mounted on the power unit and located on the solenoid valve subplate. The flow control valves will restrict the capacity of oil passing through them when the knurled knob is screwed in - in a clockwise direction. This action will reduce the linear speed of the cylinder. Turning the flow control valve adjustment in the opposite direction - anti clockwise, will increase the speed of the cylinder. One flow control valve (right side) will allow adjustment of the extension speed (travel speed should be set at minimum 20 seconds), the other (left side) the retraction speed. (Retraction speed should be set at minimum 10 seconds).

IMPORTANT

It should be noted that if the cylinder speed is restricted by the flow control valves, the balance of oil not delivered to the cylinder will go over the relief @ 825 P.S.I. which will cause unwanted heat in the reservoir.

CLEANING

 **WARNING**

Disconnect the power supply to the appliance before cleaning or servicing.

 **WARNING**

The appliance and its parts are hot. Use care when operating, cleaning and servicing the skillet.

Your kettle should be cleaned immediately after each use when cooking a different product or when cooking is completed. Before cleaning, check that the kettle has cooled enough to touch it.

1. Check that the steam supply and power supply is OFF.
2. Rinse the inside of the kettle thoroughly and drain to remove any food particles.
3. Using a nylon brush, clean the kettle with a mild detergent and water. Never use steel wool or scouring powder as it will scratch stainless steel. Plain steel wool can leave small pieces of steel which can rust.
4. Tilt the kettle to its highest position or open the tangent draw-off valve to allow the detergent and water solution to drain. Rinse thoroughly with clean water.
5. By hand, turn the large hex nut on the draw-off valve counterclockwise until it is completely disengaged from the threads. Grasp the valve knob and slowly pull out the valve stem and disk. Do not allow the disk to come in contact with hard surfaces as it can be damaged and cause valve leakage. Wash the valve stem, disk and handle. Insert a nylon brush, wet with detergent and water, into the valve body and tangent draw-off tube. Brush vigorously.
6. Replace the valve stem assembly and turn the hex nut until snug. Rinse the kettle with clean warm water.
7. Leave the draw-off valve open when the kettle is not in use.
8. Wipe the exterior of the kettle with a clean, damp cloth.
9. Never spray water into the electrical controls.

 **CAUTION**

Do not use cleaning agents that are corrosive.

Use of cleaning agents that contain chloride, acids or salts are corrosive and may cause pitting and corrosion when used over a period of time; this will reduce the life of the appliance.

Should pitting or corrosion occur this is not covered by warranty.

Follow the recommended cleaning instructions. Use a mild detergent, warm water and rinse thoroughly.

WHAT TO DO IF SURFACE RUST APPEARS

Metal utensils should never be used as they will scratch the surface of the equipment and rust may begin to form. To remove surface accumulation of rust from the inadvertent use of such utensils, the following procedure may be used.

 **WARNING**

Improper use of this procedure may damage your appliance!

1. Use undiluted white vinegar with a non-abrasive scouring pad (plastic) or cloth on the affected area to remove the rust stain. The appliance should not be heated and remain at room temperature during the entire cleaning process.
2. If the stain resists removal, additional exposure time with vinegar may be required, to a maximum of one hour.
3. Thoroughly wash all of the vinegar away with fresh clear water. Dry the surface completely and allow one hour before using the appliance to cook.

TROUBLESHOOTING

DRAW-OFF VALVE LEAKS

If leak occurs through the valve stem, replace the “O” ring. If the leak can be attributed to faulty sealing between the stem disk and valve seat, then this may be corrected by cleaning off the food residue. Another cause may be a damaged vulcanized rubber stem piece which will require replacement.

NOTICE

Draw-off valve has a vulcanized rubber coated stem for better sealing. Do not over tighten. This may cause the rubber to pull away from stem and permanently damage it. This is not covered under warranty.

EXTREMELY SLOW COOKING TIME

Abnormally slow cooking time may be due to insufficient steam pressure and/or volume. Inlet pressures of less than 10 psi will result in slow cooking performance. Note that pressures approaching the rated kettle pressure are liable to set off the safety relief valve. If required pressure is not available to kettle, then volume of steam is not sufficient. Minimum 3/4” pipe size is required to the kettle, but if the steam generating source is at a great distance from the kettle, larger pipe will be required. Also check the core of the steam supply pipe for debris or scalants that impede steam flow. May require disassembly and inspection.



HOUGHTON®

Revision Date 05-04-2018

Version 5

SAFETY DATA SHEET

SECTION 1: IDENTIFICATION OF THE SUBSTANCE/MIXTURE AND OF THE COMPANY/UNDERTAKING

Product identifier

Product Code(s)	07122000-M
Product Name	COSMOLUBRIC HF-122
Recommended Use	Fire-resistant hydraulic fluid
Uses advised against	Any other purpose.

Manufacturer, Importer, Supplier

Houghton International Inc. Madison & Van Buren Aves. Valley Forge, PA 19482 Telephone: 610-666-4000 FAX: 610-666-1376 Website: www.houghtonintl.com Customer Service: 888-459-9844	Houghton Canada 915 Meyerside Drive Mississauga ON L5T 1R8	Houghton Mexico S.A. de C.V. Efraín Gonzalez Luna, 2007 Depto19 Col. Americana, Guadalajara, Jalisco CP. 44160, Mexico Phone: +52-333-615-9331
--	--	---

Emergency telephone number

United States of America/Canada : 3E Company - 1-866-519-4752 (Code 333938)
Mexico : 3E Company - +52 55 41696225 (Code 333938)

SECTION 2: HAZARDS IDENTIFICATION

Classification

This product is not considered hazardous by the 2012 OSHA Hazard Communication Standard (29 CFR 1910.1200) and the Workplace Hazardous Materials Information System (WHMIS) 2015

Not classified

Label elements

The product contains no substances which at their given concentration, are considered to be hazardous to health

Precautionary Statements

Precautionary Statements - Response

Hazards not otherwise classified (HNOC)

Health	Not Applicable.
Physical	Not Applicable.

07122000-M - COSMOLUBRIC HF-122

Revision Date 05-04-2018

Other Information

Not applicable

SECTION 3: COMPOSITION/INFORMATION ON INGREDIENTS

The product contains no substances known to be hazardous to health in concentrations which need to be taken into account.

SECTION 4: FIRST AID MEASURES**Description of first-aid measures**

General advice	If symptoms persist, call a physician.
Inhalation	Move to fresh air.
Skin contact	Wash off immediately with soap and plenty of water. Remove and wash contaminated clothing before re-use.
Eye contact	Rinse thoroughly with plenty of water, also under the eyelids. Keep eye wide open while rinsing.
Ingestion	Clean mouth with water and afterwards drink plenty of water. Do not induce vomiting without medical advice.
Protection of First-aiders	Use personal protective equipment.

Most important symptoms and effects, both acute and delayed

Main Symptoms None

Indication of immediate medical attention and special treatment needed

Notes to physician Treat symptomatically.

SECTION 5: FIRE FIGHTING MEASURES**Extinguishing media****Suitable Extinguishing Media**

Use extinguishing measures that are appropriate to local circumstances and the surrounding environment.; Use CO2, dry chemical, or foam, Water spray or fog

Extinguishing media which shall not be used for safety reasons

None

Special hazards arising from the substance or mixture**Special Hazard**

This material creates a fire hazard because it floats on water.

Hazardous decomposition products

None under normal use

Advice for firefighters**Special protective equipment for fire-fighters**

As in any fire, wear self-contained breathing apparatus pressure-demand, MSHA/NIOSH (approved or equivalent) and full

07122000-M - COSMOLUBRIC HF-122

Revision Date 05-04-2018

protective gear

SECTION 6: ACCIDENTAL RELEASE MEASURES**Personal precautions, protective equipment and emergency procedures**

Ensure adequate ventilation.

Advice for non-emergency personnel Material can create slippery conditions.**Advice for emergency responders** For personal protection see section 8.**Environmental precautions**

Prevent further leakage or spillage if safe to do so. Do not flush into surface water or sanitary sewer system.

Methods and materials for containment and cleaning up

Soak up with inert absorbent material (e.g. sand, silica gel, acid binder, universal binder, sawdust). Dike to collect large liquid spills. After cleaning, flush away traces with water.

Reference to other sections

See Section 8/12/13 for additional information

SECTION 7: HANDLING AND STORAGE**Precautions for safe handling**

Ensure adequate ventilation. Use only in area provided with appropriate exhaust ventilation. Handle in accordance with good industrial hygiene and safety practice.

Conditions for safe storage, including any incompatibilities**Technical measures/Storage conditions**

Keep container tightly closed in a dry and well-ventilated place. Keep at temperatures between 5 and 40 °C.

Recommended Shelf Life

Shelf life 24 months.

Incompatible materials

Strong oxidizing agents, Strong acids, Strong bases

Specific end uses**Specific use(s)** Fire-resistant hydraulic fluid**SECTION 8: EXPOSURE CONTROLS/PERSONAL PROTECTION****Control parameters****Exposure Guidelines**

This product does not contain any hazardous materials with occupational exposure limits established by the region specific regulatory bodies.

07122000-M - COSMOLUBRIC HF-122

Revision Date 05-04-2018

Exposure controls

Engineering Measures Showers
 Eyewash stations
 Ventilation systems.

Individual protection measures, such as personal protective equipment

Eye/Face Protection Safety glasses with side-shields.

Skin and body protection Wear protective gloves/clothing.

Respiratory protection No special protective equipment required. In case of mist, spray or aerosol exposure wear suitable personal respiratory protection and protective suit.

Hygiene measures Handle in accordance with good industrial hygiene and safety practice.

SECTION 9: PHYSICAL AND CHEMICAL PROPERTIESInformation on basic physical and chemical properties

Physical state	liquid	Appearance	clear , amber
Odor	bland	Odor threshold	Not Determined

<u>Property</u>	<u>Values</u>	<u>Remarks</u>
pH	Not applicable	
Melting point / freezing point	-33 °C / -27 °F	
Boiling point / boiling range	Not Determined	
Flash point	> 319 °C / > 606 °F	Cleveland Open Cup
Evaporation rate	Not Determined	
Flammability (solid, gas)	Not Determined	
Flammability Limit in Air		
Upper flammability limit:	Not Determined	
Lower flammability limit:	Not Determined	
Vapor pressure	Not Determined	
Vapor density	Not Determined	
Relative density	0.917	g/cm ³ @20°C
Solubility(ies)	Insoluble in water	
Partition coefficient	Not Determined	
Autoignition temperature	Not Determined	
Decomposition temperature	Not Determined	
Kinematic viscosity	>= 49.53 cSt @ 40 °C	ASTM D 445
Explosive properties	Not applicable	
Oxidizing Properties	Not applicable	

Other Information

Viscosity, kinematic (100°C)	Not Determined
Pour Point	-33 °C / -27 °F
VOC Content (ASTM E-1868-10)	Not Determined
VOC content	Not Determined

SECTION 10: STABILITY AND REACTIVITYReactivity

None under normal use conditions

Chemical stability

07122000-M - COSMOLUBRIC HF-122

Revision Date 05-04-2018

Stable under normal conditions

Possibility of hazardous reactions

None under normal use conditions

Conditions to avoid

Keep away from open flames, hot surfaces and sources of ignition

Incompatible materials

Strong oxidizing agents, Strong acids, Strong bases

Hazardous decomposition products

None under normal use conditions

SECTION 11: TOXICOLOGICAL INFORMATION**Information on likely routes of exposure**

Product Information	There is no data available for this product.
Inhalation	Based on available data, the classification criteria are not met
Eye contact	Based on available data, the classification criteria are not met
Skin contact	Based on available data, the classification criteria are not met
Ingestion	Based on available data, the classification criteria are not met
Component Information	Non-hazardous ingredients

Information on toxicological effects

Symptoms No information available.

Delayed and immediate effects as well as chronic effects from short and long-term exposure

Skin corrosion/irritation	Based on available data, the classification criteria are not met.
Serious eye damage/eye irritation	Based on available data, the classification criteria are not met
Sensitization	Based on available data, the classification criteria are not met.
Germ cell mutagenicity	Based on available data, the classification criteria are not met.
Carcinogenicity	Based on available data, the classification criteria are not met.
Reproductive toxicity	Based on available data, the classification criteria are not met.
Specific target organ toxicity (single exposure)	Based on available data, the classification criteria are not met.
Specific target organ toxicity (repeated exposure)	Based on available data, the classification criteria are not met.
Aspiration hazard	Based on available data, the classification criteria are not met.

07122000-M - COSMOLUBRIC HF-122

Revision Date 05-04-2018

SECTION 12: ECOLOGICAL INFORMATIONEcotoxicity

No special environmental measures are necessary

Persistence and degradability No information available.Bioaccumulation No information availableMobility The product is insoluble and floats on water. Is not likely mobile in the environment due its low water solubility.Other adverse effects No information available**SECTION 13: DISPOSAL CONSIDERATIONS**Waste treatment methodsWaste Disposal Methods Dispose of in accordance with federal, state and local regulations.Contaminated packaging Observe all label precautions until container is cleaned, reconditioned or destroyed.**SECTION 14: TRANSPORT INFORMATION**DOT Not RegulatedTDG Not RegulatedMEX Not RegulatedIATA Not RegulatedIMDG Not Regulated**SECTION 15: REGULATORY INFORMATION**International InventoriesInventory information may be utilizing alternative CAS#s or exemptions beyond those stated within this document For further information, please contact: ProductStewardship@houghtonintl.com

TSCA	Complies
DSL	Complies
AICS	Complies
PICCS	Complies
KECL	Complies
IECSC	Complies
ENCS	Does not Comply
TCSI	Complies
NZIoC	Does not Comply

Legend:

07122000-M - COSMOLUBRIC HF-122

Revision Date 05-04-2018

TSCA - United States Toxic Substances Control Act Section 8(b) Inventory
DSL/NDSL - Canadian Domestic Substances List/Non-Domestic Substances List
AICS - Australian Inventory of Chemical Substances
PICCS - Philippines Inventory of Chemicals and Chemical Substances
KECL - Korean Existing and Evaluated Chemical Substances
IECSC - China Inventory of Existing Chemical Substances
ENCS - Japan Existing and New Chemical Substances
TCSI - Taiwan National Existing Chemical Inventory
NZIoC - New Zealand Inventory of Chemicals

U.S. Federal Regulations

SARA 313

Section 313 of Title III of the Superfund Amendments and Reauthorization Act of 1986 (SARA). This product does not contain any chemicals which are subject to the reporting requirements of the Act and Title 40 of the Code of Federal Regulations, Part 372.

SARA 311/312 Hazard Categories

- No EPCRA 311/312 hazards

Clean Water Act

This product does not contain any substances regulated as pollutants pursuant to the Clean Water Act (40 CFR 122.21 and 40 CFR 122.42).

CERCLA

To the best of our knowledge, this product does not contain chemicals at levels which require reporting under this regulation, Comprehensive Environmental Response Compensation and Liability Act (CERCLA) (40 CFR 302) or the Superfund Amendments and Reauthorization Act (SARA) (40 CFR 355). There may be specific reporting requirements at the local, regional, or state level pertaining to releases of this material.

U.S. State Regulations

SCAQMD Rule 1144

This product has not been tested for VOC content by the ASTM E-1868-10 method and is not approved for sale or distribution in the SCAQM District of California if the product is used as a metal forming, metal removal, metal treating, metal protection fluid or as a direct-contact lubricant.

California Proposition 65

This product does not contain any Proposition 65 chemicals.

International Regulations

Ozone-depleting substances (ODS)

Not applicable

Persistent Organic Pollutants

Not applicable

Chemicals Subject to Prior Informed Consent (PIC)

Not applicable

Other Information

Not applicable

SECTION 16: OTHER INFORMATION

07122000-M - COSMOLUBRIC HF-122

Revision Date 05-04-2018

<u>NFPA</u>	Health hazards 0	Flammability 1	Instability 0	Physical and chemical properties -
-------------	------------------	----------------	---------------	------------------------------------

Key or legend to abbreviations and acronyms used in the safety data sheet

STOT SE - Specific target organ systemic toxicity (Single exposure)
STOT RE - Specific target organ systemic toxicity (repeated exposure)
VOC - Volatile organic compounds
NIOSH IDLH: Immediately Dangerous to Life or Health

Revision Date 05-04-2018

Revision Note This SDS has been revised in the following section(s), 2, 3, 8, 11

Disclaimer

The information provided in this Safety Data Sheet is correct to the best of our knowledge, information and belief at the date of its publication. The information given is designed only as a guidance for safe handling, use, processing, storage, transportation, disposal and release and is not to be considered a warranty or quality specification. The information relates only to the specific material designated and may not be valid for such material used in combination with any other materials or in any process, unless specified in the text.

End of Safety Data Sheet

DMT-30S, DMT-40S, DMT-60S DMS-30S, DMS-40S & DMS-60S Direct Steam Power Tilting or Stationary Kettles



A product with the Southbend Steam name incorporates the best in durability and low maintenance. We all recognize, however, that replacement parts and occasional professional service may be necessary to extend the useful life of this appliance. When service is needed, contact a Southbend Steam Authorized Service Agency, or your dealer. To avoid confusion, always refer to the model number, serial number, and type of your appliance.



SOUTHBEND STEAM
 **MIDDLEBY** A Middleby Company
1100 Old Honeycutt Road Fuquay-Varina, North Carolina 27526 USA
www.southbendnc.com